

---

# Lift-A-Lift® Fork Lift Service Lift

## Fast, Safe and Easy Maintenance for Fork Lifts • Industrial Vehicles • Light Trucks

Tilt-or-Lift, Inc., the leading designer of specialty lifts for over 20 years, has raised the art of fork lift maintenance to new heights with the *Lift-A-Lift*® fork lift service lift.

The *Lift-A-Lift* service lift is designed to allow complete access to underside parts of fork lifts, industrial trucks and motor vehicles for lubrication, repair or part replacement. Just drive the vehicle onto the adjustable runways. The self-leveling lift raises the vehicle up to 72 inches, so all maintenance can be performed while standing.

## High Marks for Safety and Versatility

The *Lift-A-Lift* service lift complies with applicable ANSI and OSHA requirements. Automatic safety pawls are incorporated in the design to prevent accidents in the event of hydraulic failure.

The *Lift-A-Lift* service lift is portable and has removable runway panels and floor beam for easier access. Standard 18 inches wide runways adjust hydraulically from 56 to 76 inches (outside dimension) to accommodate a wide range of vehicles. The lift is available in two models; a variety of popular options is available to enhance its utility. All lifts are shipped assembled and factory tested and carry a full one-year warranty.

The *Lift-A-Lift* service lift; one of the fine family of fork lift service lifts available from Tilt-or-Lift, Inc., the lift specialists. There are no finer lifts available – anywhere.

**“We stand under our products.”**



**Manufacturers of  
Fork Lift Maintenance Lifts**

P.O. Box 8728  
Maumee, Ohio 43537-8728

Telephone: (419) 893-6944  
Fax: (419) 893-5714



# Lift-A-Lift® Fork Lift Service Lift

## Specifications

- Capacity:  
20,000 lbs. G.V.W.  
(Model V-20-A)  
30,000 lbs. G.V.W.  
(Model V-30-A)
- Minimum ceiling height: 12' 10"
- Ramp: length 5'
- Vertical travel: 72" maximum
- Safety locks: automatic
- Motor: 5 H.P.  
Power: 3-phase only
- Shipping weights: (Approx.)  
7300 lbs. (V-20-A)  
8000 lbs. (V-30-A)

## Features

- Portable, hydraulic lift
- 20" to 40" inside working width
- Auto safety locks
- Auto self-leveling system
- 18" wide runways adjust from 56" to 76" (outside dimension)
- Removable runway panels
- Lockable control panel
- Wheel freeing device
- Shipped assembled and factory tested

## Options

- Hydraulic motor/transmission jack
- Ramp - 10' long
- Pallet jack combo kit  
- center ramp & 2 side rails

All units are subject to change and modifications

**Note:** Dimensions may change without notice.

U.S. Patent No. 4,134,501

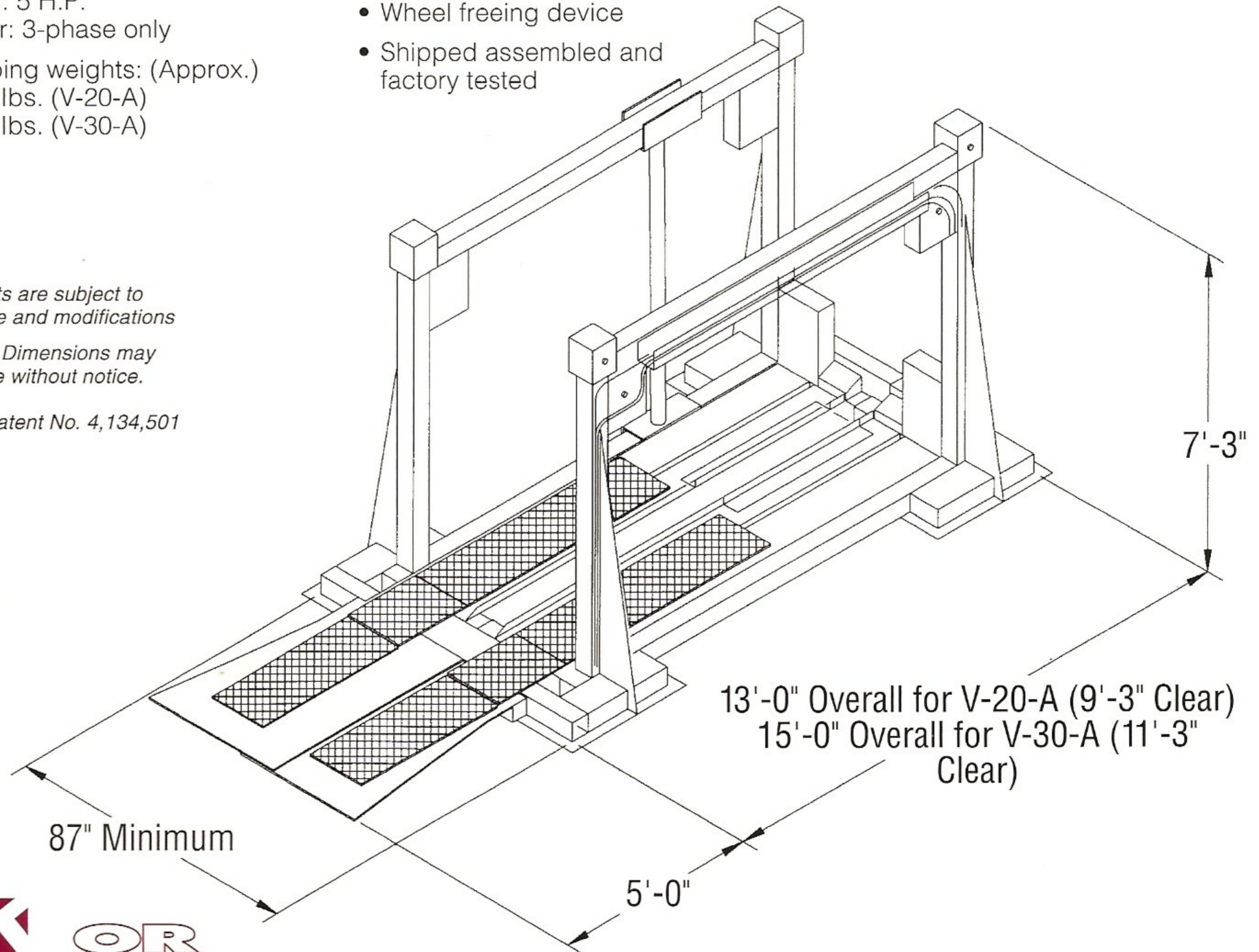

**Manufacturers of  
Fork Lift Maintenance Lifts**

P.O. Box 8728  
Maumee, Ohio 43537-8728

Telephone: (419) 893-6944  
Fax: (419) 893-5714

Tilt-A-Lift®, Lift-A-Lift®, Tipper™, Tilter™